

Comparison of Swirl Tube and Hypervapotron for Cooling of ITER Divertor*

C.B. Baxi

General Atomics

P.O. Box 85608, San Diego, California 92186-9784

ABSTRACT

The ITER divertor will have a peak steady state heat flux of 5 MW/m^2 and a heat flux of 15 MW/m^2 for up to 10 s duration. Cooling will be provided by water at an inlet temperature of 150°C and a pressure of 4 MPa. A heat transfer enhancement technique is required in order to achieve a sufficient margin on critical heat flux at a reasonable flow velocity. Hypervapotron (HV) and swirl tube (ST) are under consideration as enhancement methods. There are many fundamental differences between these two devices, such as: (a) The ratio of surface heat flux to coolant channel heat flux, (b) the flow area per unit heat flux area, (c) critical heat flux (CHF) and (d) the pressure drop. This paper presents new CHF correlations for ST and HV concepts and compares them to the available experimental data. The friction factor correlation for ST is well known. A new friction factor correlation for HV based on existing data is presented.

A comparison of the two concepts was performed for ITER conditions based on equal heat flux area. The comparison shows that the pumping power required for HV is slightly higher (about 10%) and the incident critical heat flux (ICHF) is slightly lower (8%) for HV compared to ST at similar flow conditions. These differences are small enough and uncertainties in data large enough so that the choice between the two concepts should be based on other considerations such as: (1) cost and ease of fabrication, (2) ease of brazing and (3) volume and reliability of available experimental data. These considerations lead to the conclusion that the choice of concept will depend on the particular application. For ITER, both of these concepts could be used in different areas of the divertor.

INTRODUCTION

A large number of experiments have been carried out on the swirl tube (ST) concept. The data on the HV is relatively scarce and does not include any data at ITER relevant pressures and temperatures, although experiments are planned in next few months. An comparison of these two concepts (Fig. 1) is presented in this paper.

Comparison of HV and ST is difficult due to of many fundamental differences between these two devices. These are:

1) The ratio of surface heat flux to coolant channel heat flux: For the case of swirl tube coolant channels as applied to fusion devices this ratio depends on flow velocity,

component concept (mono block, flat block, macro block etc.), the plasma facing material, and the level of heat transfer coefficient in the channel. For ITER conditions, this ratio is about 1.5. On the other hand, this ratio is close to 1.0 for HV.

2) Flow area: The area for HV is considerably smaller.

3) Critical Heat Flux: The classical definition of the CHF is "heat flux at which the surface temperature starts rising rapidly" [1]. The wall critical heat flux (WCHF) is the CHF at the coolant channel wall. The incident critical heat flux (ICHF) is the CHF on the surface of the plasma facing component. We propose new correlations for CHF for both these concepts and compare them to experiments.

4) The pressure drop for these two concepts at given flow conditions are different for these two concepts.

Finally to compare the two concepts we will compare the ICHF and pumping power at a given velocity for ITER conditions.

CORRELATIONS

Consider the HV and ST geometries shown in Fig. 1. The heat flux area has been chosen to be equal. The length of the devices will be assumed to be 1.2 m, which is typical of ITER.

For the case of twisted tape in a tube with inside diameter of D with a tape thickness t , the hydraulic diameter is:

$$DH_{ST} = \left(\pi D^2 - 4tD \right) / \left(\pi D + 2D - 2t \right) \quad (1)$$

The hydraulic diameter for the HV with a channel height of h and a width of w is:

$$DH_{HV} = 2(h \cdot w) / (h + w) \quad (2)$$

A slightly different definition of hydraulic diameter, which takes into account the wetted perimeter of the fins, is possible but earlier works [3–6] have used the above definition.

After reviewing the existing data on HV [2–7] we propose the following correlations for friction factor in HV devices:

$$f_{HV} = 0.613 \text{Re}^{-0.2} \quad (3)$$

*Work supported by ITER Contract No. Y3E034R.

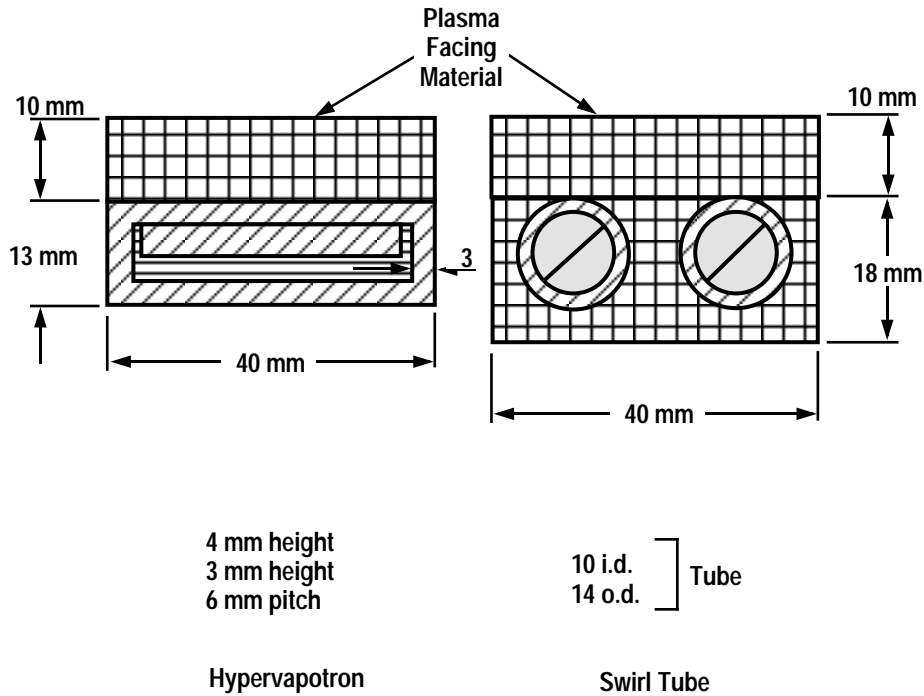

Fig. 1. Hypervapotron and swirl tube geometry.

where, Re = Reynolds number
 $= VDH/\nu$
 v = average flow velocity
 ν = kinematic viscosity

Recent experiments at the University of Illinois [8], agree within 10% with the above correlation.

The friction factor for ST will be calculated by following Lopina – Bergles correlation [9]:

$$f_{ST} = 0.512Re^{-0.2}Y^{-0.406} \quad (4)$$

where Y is the twist ratio defined as the number of tube diameters per 180° twist. Looking at experimental data for ICHF of HV, we propose a following correlation for a typical HV (copper HV, fin height 4 mm, fin width 3 mm and fin pitch = 6 mm):

$$ICHF_{HV} = C(Re)^{n1}(DH/Do)^{n2}(Ja)^{n3} \quad (5)$$

In the above correlation the Jacob number $Ja = -X_{sub}(\rho_l/\rho_v)$. Where $C = 0.0091$, $n1 = 0.45$, $n2 = -0.25$, $n3 = 0.75$, $Do = 0.0055$ m; X_{sub} = quality of the coolant; ρ_v = density of the vapor; ρ_l = density of the liquid.

This is the first correlation proposed to predict the CHF for HV. A comparison of the above correlation to the data from three experiments [5–7] is shown in Fig. 2. As more data becomes available, the above correlation could be improved. Other parameters which need to be included are fin height, width and pitch and perhaps length.

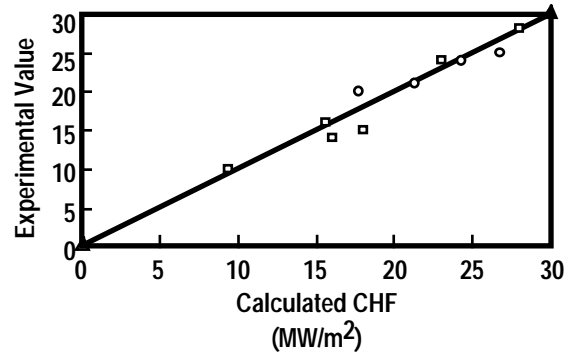

Fig. 2. Comparison of proposed CHF correlation for hypervapotron with experimental data.

For the CHF of ST, we propose a following correlation:

$$CHF_{ST} = 0.23 f_o G H_{fg} \left(1 + 0.00216 pr^{1.8} Re^{0.5} Ja \right) \left(1 + 0.87/Y^{0.4} \right) \quad (6)$$

where $f_o = 8Re^{-0.6} (DH/0.00127)^{0.32}$

pr = ratio of coolant pressure to critical pressure

G = mass flux, $kg/m^2\cdot s$

H_{fg} = latent heat of water, kJ/kg

The above correlation has been obtained by modifying the TONG-75 [10] by an enhancement factor to account for effect of swirl tape. A comparison of critical heat flux calculated by the above equation and experimental results of Schlosser *et al.* [11] is shown in Fig. 3. The above correlation is better than existing correlations because 1) it shows better agreement with experimental results in flow range of interest

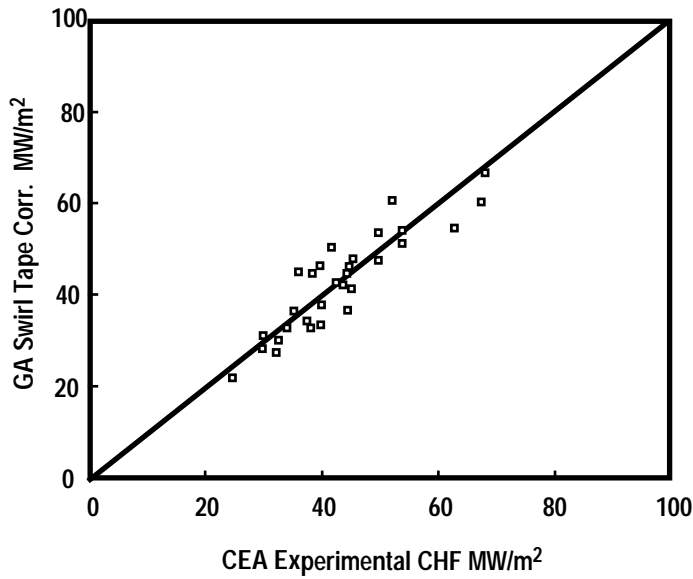

Fig. 3. Comparison of proposed CHF correlation for swirl tube with experimental data.

to fusion devices and 2) the CHF value calculated by this correlation approaches to smooth tube results when Y is large.

COMPARISON

With the above correlations, it is now possible to compare the thermal hydraulic performance of these two devices for different flow velocities and sub cooling. We will assume that the length is 1.2 m, the average heat flux is 2 MW/m^2 , water pressure at inlet is 4 MPa, and inlet water temperature is 150°C . A flow velocity range of 5 to 15 m/s is assumed.

A. Flow Areas

$$A_{\text{HD}} = 102 \text{ mm}^2$$

$$A_{\text{ST}} = 141 \text{ mm}^2$$

B. Hydraulic Diameters

$$DH_{\text{HV}} = 5.51 \text{ mm}$$

$$DH_{\text{ST}} = 5.66 \text{ mm}$$

C. Flow Rates

The flow in ST is larger by 38%. At 10 m/s the values are $\text{FLOW}_{\text{HV}} = 0.979 \text{ kg/s}$; $\text{FLOW}_{\text{ST}} = 1.353 \text{ kg/s}$.

D. Coolant Temperature Rise

At 10 m/s the values are $\Delta T_{\text{BHV}} = 22.8^\circ\text{C}$; $\Delta T_{\text{BST}} = 16.5^\circ\text{C}$

E. Pumping Power

Pumping power is given by $W = \Delta P \text{Flow} / \rho$ where ρ = density, kg/m^3 and ΔP = pressure drop, Pa

For the flow length of 1.2 m, the comparison of pumping power for the two concepts is shown in Fig. 4. The flow rate for HV is less but the pressure drop is larger and hence the pumping power is slightly (about 10%) larger.

ICHF

The CHF depends on pressure and temperature and is minimum at exit. A computer program calculated these conditions at the exit and then calculated the CHF at exit for a velocity range of 5 to 15 m/s. Finite element analysis shows that ICHF is about 1.5 times the WCHF. For ST the wall CHF was divided by 1.5 to obtain the ICHF. The results are shown in Fig. 5. The ICHF for HV is slightly (about 8%) lower than ICHF for ST at a given velocity.

OTHER CONSIDERATIONS

Other than thermal hydraulic performance, the following factors will decide the choice between HV and ST.

- 1) Fabrication cost and simplicity. Costs of the devices are about equal. Fabrication of ST is simpler.
- 2) Brazing. For the monoblock geometry, brazing will be difficult for ST. If the flat block is used, ST and HV are comparable.

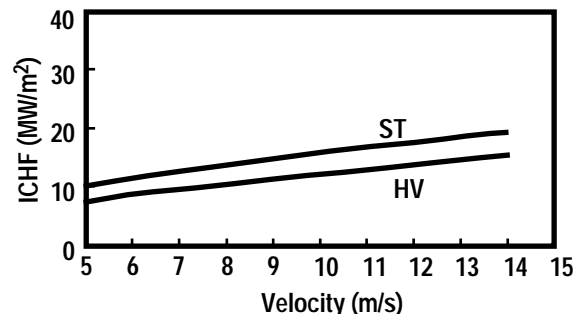

Fig. 4. Pumping power.

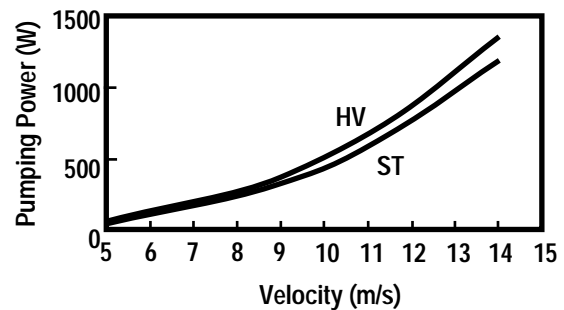

Fig. 5. ICHF.

- 3) The peak localized temperature of plasma facing material for HV will be slightly lower due to shorter distance from cooled surface to the corner of PFC.
- 4) Manifolding is easier for HV.

CONCLUSIONS

- 1) For similar flow velocity and inlet temperature and pressure the pumping power required for HV is about 10% higher and the critical heat flux on the surface is about 8% lower. This is within the uncertainties of correlations and experimental data.
- 2) More accurate correlations for HV are required.
- 3) This study shows that HV and ST are comparable for ICHF and pumping power.
- 4) The choice between these two devices may depend on factors other than thermal hydraulic considerations, such as brazing, cost and manifolding. For brazing, the HV is better. Costs of the two devices are about equal and complexity of manifolding will depend on the application. In general, the ST is a better device than HV. However, for the ITER divertor, a combination of these devices may be suitable due

to geometry. For vertical target and vanes, ST is a better choice. For Dome the HV may be preferred due to manifolding considerations.

REFERENCES

- [1] J.G. Collier, "Convective boiling and condensation," McGraw-Hill, New York, 1972.
- [2] C.B. Baxi and H. Falter "A model for analytical performance prediction of hypervapotron," Fifth Int. Meeting on Nuclear Thermal Hydraulics, September 1992.
- [3] H. Falter *et al.*, "Thermal test results of the JET divertor plates," SPIE, San Diego, 1992.
- [4] A. Cardella, G.P. Celata, G.P. Gaspari, "Tests on the hypervapotron," 1990 Symp. on Fusion Technology, London.
- [5] G. Cattadori *et al.*, "Visualization of hypervapotron effect," presented at 2nd Specialists WS on fusion thermal hydraulics, 1992.
- [6] S. Gaspari, "private communication," February 1993.
- [7] M. Araki, "private communication," December 1994.
- [8] D. Driemeyer, "Hypervapotron flow testing with rapid prototype modeling," this conference.
- [9] R.F. Lopina and A.E. Bergles, "Heat transfer and pressure drop in tape generated swirl flow in single phase water," Presented at 6th Int. HT conference, Boston (1963).
- [10] L.S. Tong, "A phenomenological study of critical heat flux," ASME Paper, 75-HT-68, 1975.
- [11] J. Schlosser *et al.*, Symp. on Fusion Technology, Karlsruhe.